

POWER STEERING LINK (for 2WD)

COMPONENTS

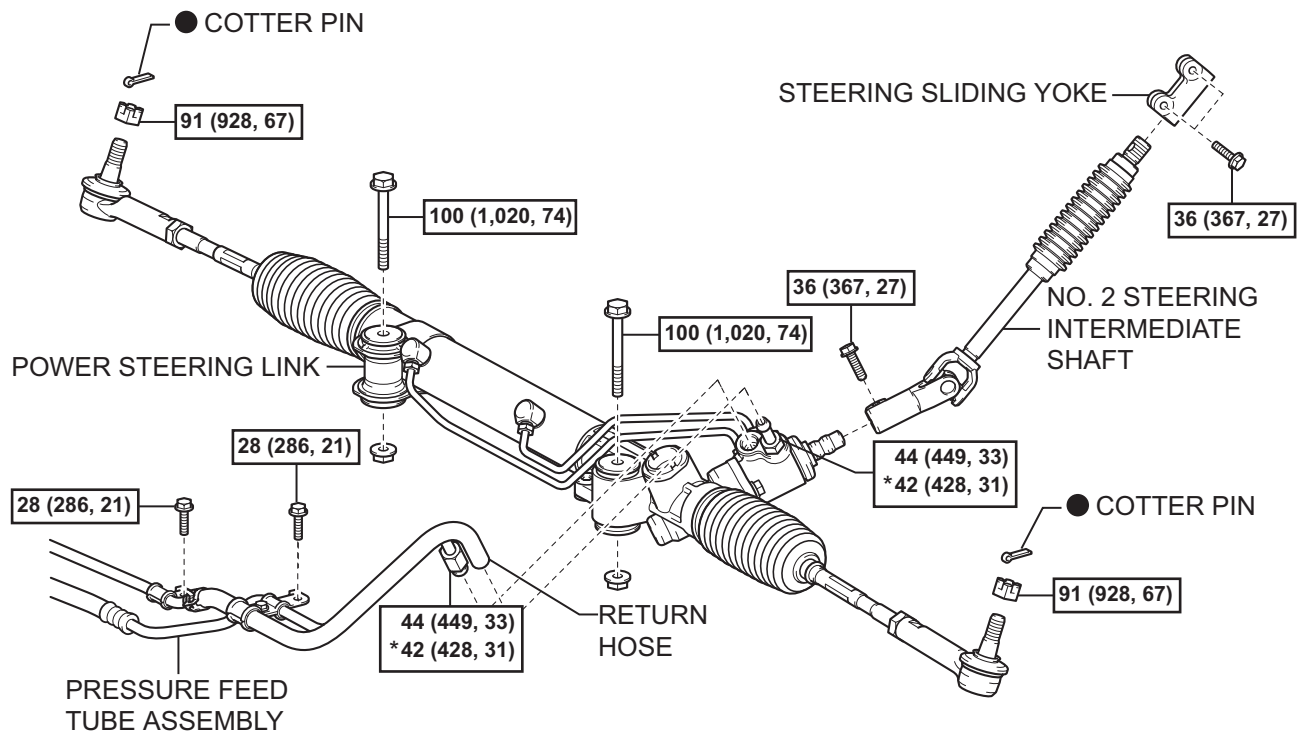

N*m (kgf*cm, ft*lbf) : Specified torque ● Non-reusable part * For use with SST

PS

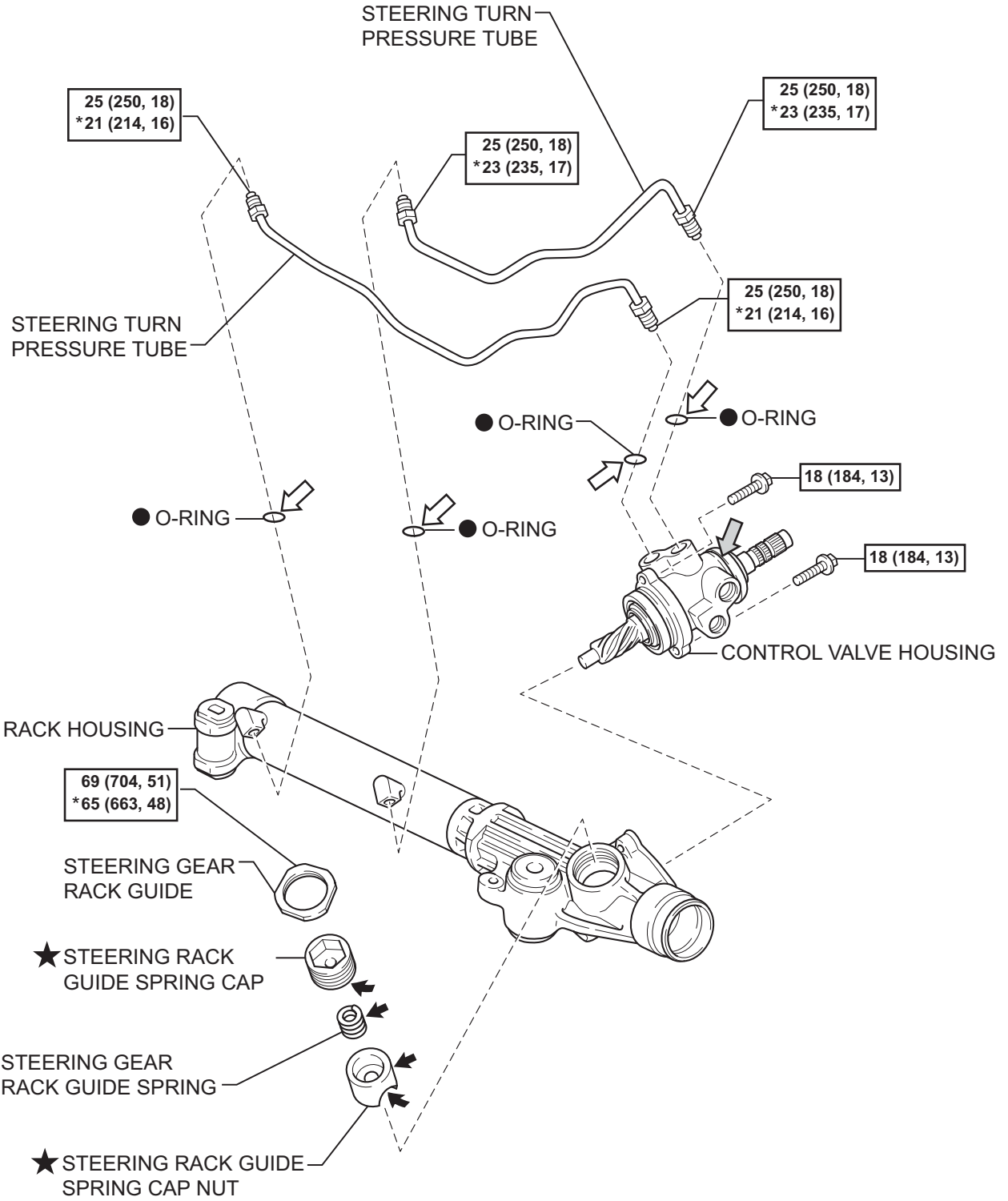

N*m (kgf*cm, ft*lbf) : Specified torque

← Molybdenum disulfide lithium base grease * For use with SST

● Non-reusable part

← Power steering fluid

★ Precoated part

← MP grease

